



CC2824D225R-10

UNCONTROLLED DOCUMENT

ELECTRICAL SPECIFICATION @ 25°C
OPERATING TEMPERATURE RANGE: 0°C TO +125°C

PARAMETER SYMBOL	TEST LEADS	CONDITIONS	REQUIREMENTS		
			MIN	TYP	MAX
Lp (μH)	1-4/2-3	@ 10KHz/ 50mV	1540	2200	3300
L LEAKAGE (μH)	1-4 (s' 2-3)	@ 10KHz/ 50mV		0.25	
TRP			1 : 1 +/- 5%		
DCR(Ω)	1-4/2-3			0.40	0.52
Hi-pot	wdg-wdg	(Vac) .5mA, 2sec.	750		
I (mA)					500

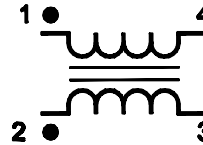
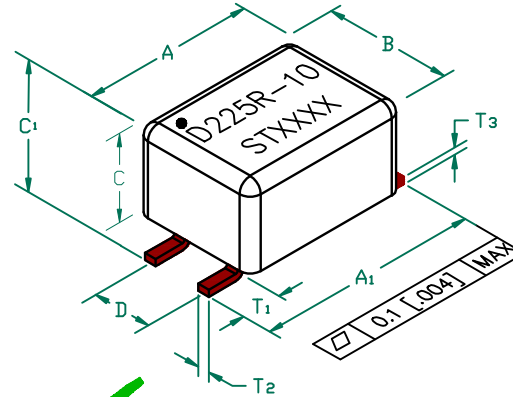

PHYSICAL DIMENSIONS:

A	7.50 [.295]	±	MAX.
A ₁	9.00 [.354]	±	0.40 [.016]
B	5.50 [.217]	±	MAX.
C	3.80 [.150]	±	MAX.
C ₁	4.90 [.193]	±	MAX.
D	2.54 [.100]	±	0.10 [.004]
T ₁	1.75 [.069]	±	TYP.
T ₂	0.50 [.020]	±	0.10 [.004]
T ₃	0.30 [.012]	±	0.10 [.004]

WEIGHT/1000 0.28 kgs [.62 Lbs]

NOTES: UNLESS OTHERWISE SPECIFIED

1. TAPED AND REELED ON 13" REELS, 1500 PCS/REEL.
2. OPEN BOTTOM CONSTRUCTION.

Typical Insertion Loss @ 50 ohm

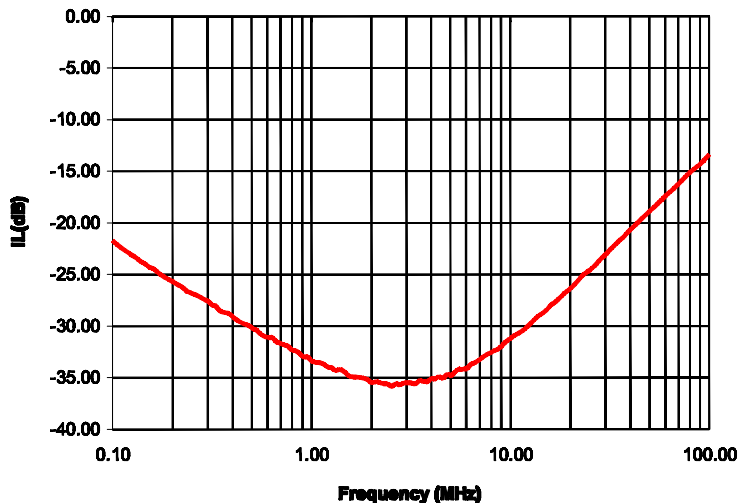

LAND PATTERNS FOR REFLOW SOLDERING

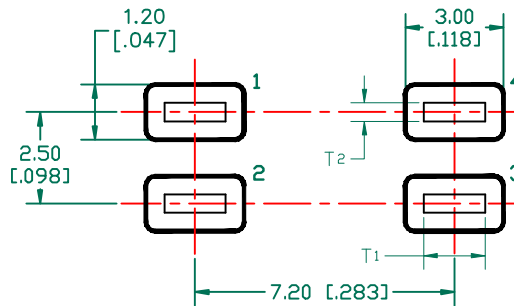

RECOMMENDED SOLDERING CONDITIONS

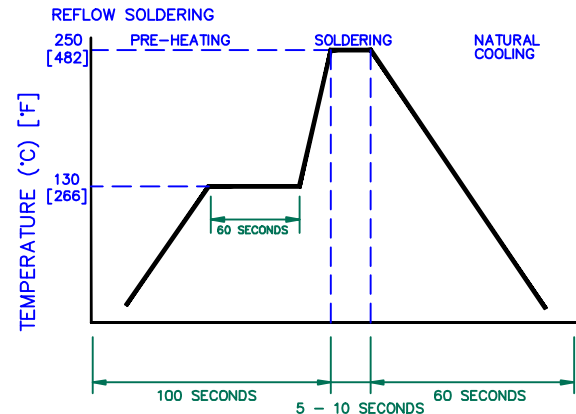

DIMENSIONS ARE IN mm [INCHES].				This print is the property of Laird Tech. and is loaned in confidence subject to return upon request and with the understanding that no copies shall be made without the written consent of Laird Tech. All rights to design or invention are reserved.			
D	UPDATE COMPANY LOGO CHG T2 AND T3 PLACEMENT ON PART	2/11/08	JRK	PROJECT/PART NUMBER:	REV	PART TYPE:	DRAWN BY:
C	UPDATE COMPANY LOGO	05/08/07	JRK	CC2824D225R-10	D	ASSEMBLY	JRK
B	CHANGE T3 DIMENSION	07/26/05	JRK	DATE:	06/07/05	SCALE:	NTS
A	ORIGINAL DRAFT	06/07/05	JRK	CAD #	CC2824E513R-10-D	TOOL #	-
REV	DESCRIPTION	DATE	INT			2 of 2	

